

# EXTENTION FIBER GLASS ALUMINUM LADDER.

**LOAD CAPACITY**  
150 KG

**MATERIAL**  
ALUMINUM

**CLASS**  
EN131  
COMMERCIAL  
150kg

**ANTI SLIP**

## Features

High-strength insulation materials construction.

The ladder mostly used in power sector and fire department.

The hinges consist of high strength steel panel, and can be used as extension ladder and straight ladder.

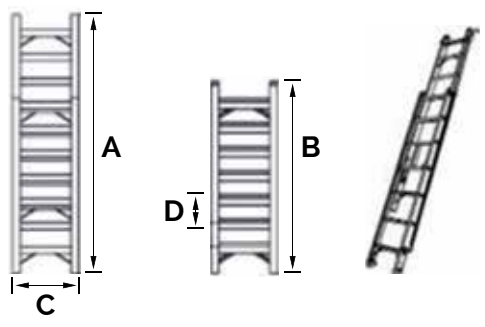

CODE	STEPS	A SIZE	B SIZE	C SIZE	D SIZE	N.W.
		(CM)				(KG)
LAD-DLT-40-XX	4	400	270	43	31	16.5
LAD-DLT-60-XX	6	600	360	43	31	24
LAD-DLT-80-XX	8	800	460	43	31	31



www.cke.co.id